







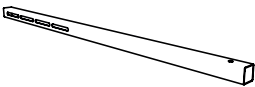

ASSEMBLY INSTRUCTIONS

Ref. no. 0458-395-0241

COMPONENTS

	_____	1 x	_____	03-02787
	_____	1 x	_____	03-02786
	_____	1 x	_____	03-02783
	_____	1 x	_____	03-02785
	_____	1 x	_____	Allen bolt M5x10
	_____	1 x	_____	Allen bolt M5x16
	_____	8 x	_____	Allen bolt M8x16
	_____	1 x	_____	Tube end cap
	_____	8 x	_____	Flange lock nut M8
	_____	1 x	_____	Magnet





 Bolt bag
 Bar nose steering

BAR NOSE STEERING

SAW UNITS

ASSEMBLY: BAR NOSE STEERING

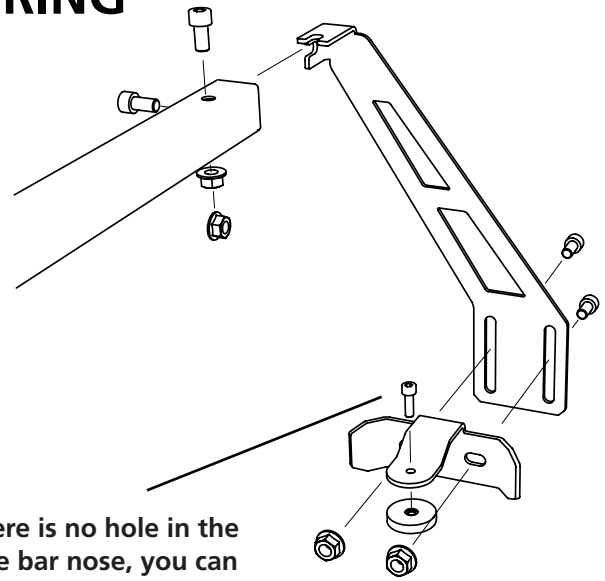

1

-  — 1 x — Allen bolt M5x16 or M5x10
-  — 4 x — Allen bolt M8x16
-  — 4 x — Flange lock nut M8
-  — 1 x — Magnet



If there is no hole in the guide bar nose, you can use a shorter bolt that does not protrude below the magnet.

2

-  — 2 x — Allen bolt M8x16
-  — 2 x — Flange lock nut M8

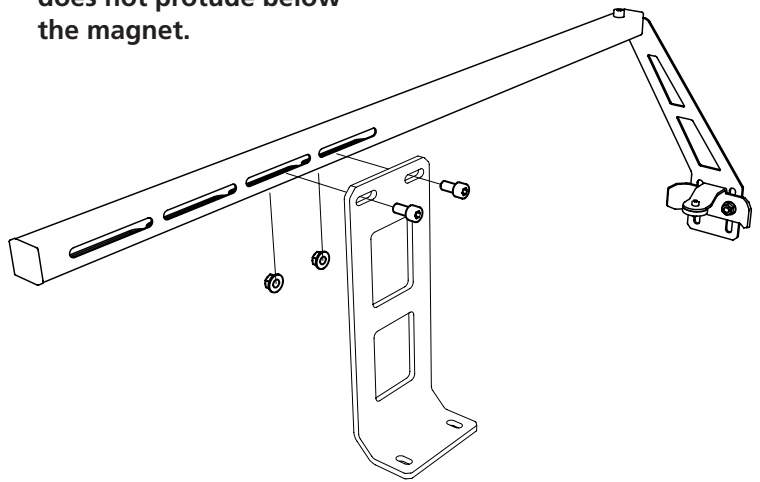

3

Fit the tube end cap to the bar nose steering tube.

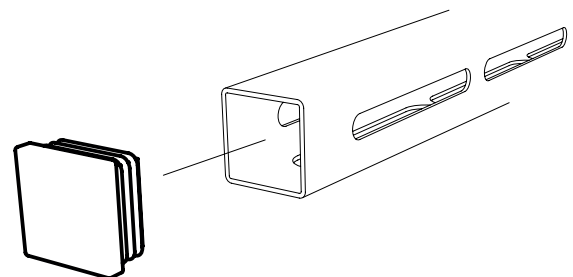

ASSEMBLY: BAR NOSE STEERING

Installing the bar nose steering onto a chainsaw carriage.

-  — 2 x — Allen bolt M8x16
-  — 2 x — Flange lock nut M8

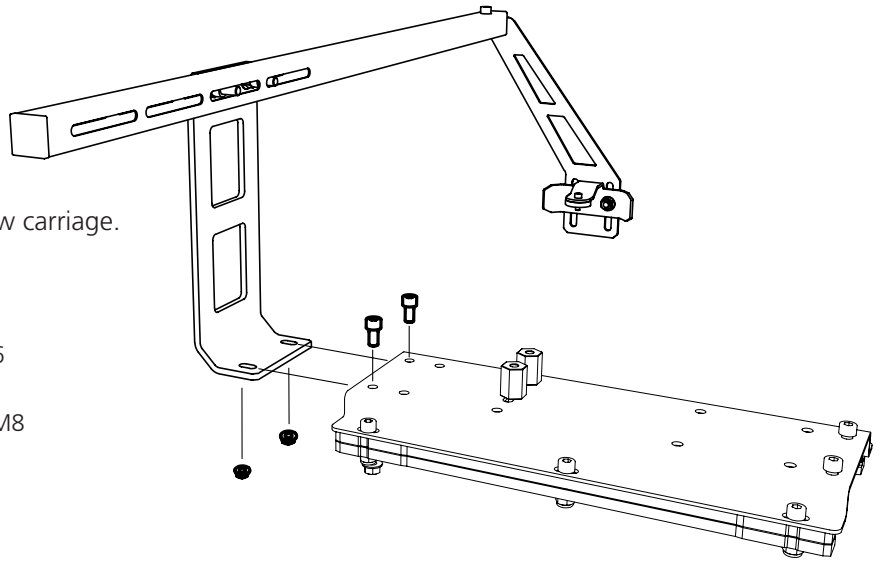

Installing the bar nose steering onto an electric saw carriage.

-  — 2 x — Allen bolt M8x16
-  — 2 x — Flange lock nut M8

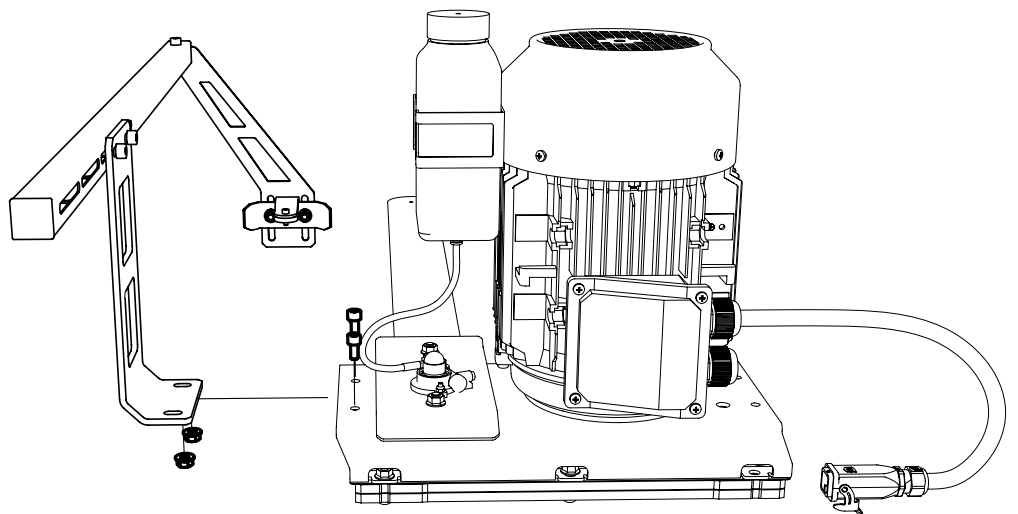

ADJUSTMENTS

With the magnet holder on the bar nose steering you can adjust the the bar nose attachment in height and sideways.

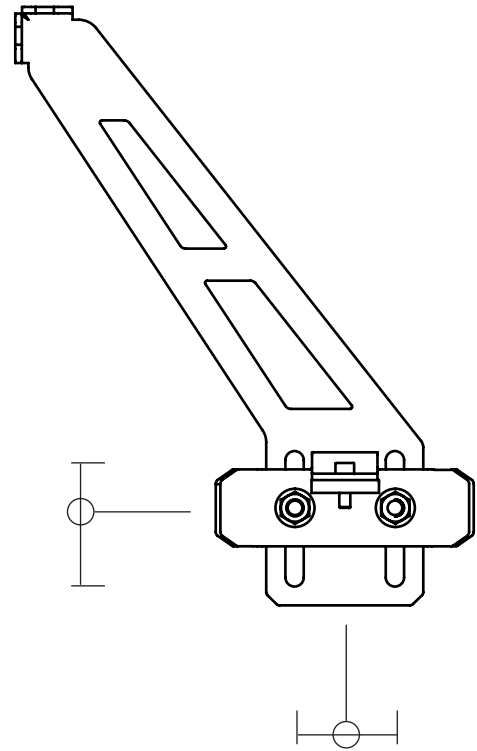

In the tube of the bar nose steering there are oblong holes. Adjust the position of the bar nose steering tube, so that the bolt through the magnet comes into place in the hole in the guide bar nose.

If there is no hole in the guide bar nose, you can use a shorter bolt that does not protude below the magnet.

